

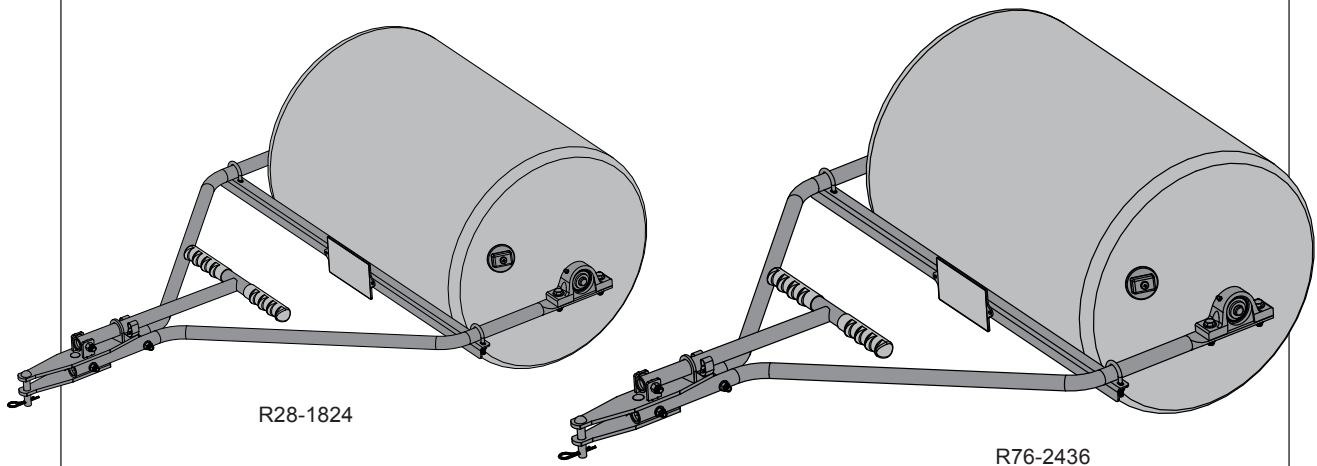

OPERATOR'S MANUAL

R28-1824 and R76-2436 Rollers



Spyker Spreaders

Contact us at 800.972.6130
www.spyker.com

▲ IMPORTANT

**This manual contains information for the safety of persons and property.
Read it carefully before assembly and operation of the equipment!**

TABLE OF CONTENTS

Safety 2

Parts 3-4

Assembly 5-7

Use and Care 8-9

 Operation 8

 Maintenance 9

 Storage 9

Warranty 10



This symbol helps point out important safety precautions throughout this manual. It means:
ATTENTION!
BECOME ALERT!
 Your safety is involved.



Tools Required for Assembly:

Wrenches or Deep Sockets:

- (x1) 1/4"
- (x1) 5/16"
- (x1) 7/16"
- (x2) 1/2"
- (x2) 9/16"

SAFETY

PREPARATION:

- Know controls and how to stop safely.
- READ THE OWNER'S MANUAL before operating.
- Do not fill roller to a weight greater than you can handle and control comfortably.
- Keep the vehicle & attachment in good operating condition & keep safety devices in place.
- Keep all nuts, bolts and screws tight to be sure the equipment is in safe working condition.
- See tractor equipment owner's manual for safe operation of the equipment and be sure that the tractor you are using is capable of towing the roller.

WHILE IN USE:

- Never use roller up and down hills; always work across hills and slopes.
- Use caution while turning, slowing or stopping.
- Avoid crossing rocky areas, gravel driveways or paved areas to prevent denting or puncturing the roller.
- Stay alert for holes in the terrain and other hidden hazards.
- Do not drive close to creeks, ditches and public highways.
- Watch out for traffic when crossing or near roadways.
- After striking a foreign object: The vehicle and attachment should be stopped and inspected for damage. *NOTE: The damage should be repaired before restarting and operating the equipment.*

PROTECT YOURSELF AND OTHERS:

- Do not allow children to operate the vehicle.
- Do not allow adults to operate without proper instruction or without having read the owner's manual.
- Do not carry passengers.
- Be sure the area is clear of pets and people, especially young children. Never assume they will remain where you last saw them. Stop using the roller if any enter the area.
- Always wear substantial footwear.
- Do not wear loose fitting clothing that can get caught in moving parts.
- Keep your eyes and mind on your tractor / attachment and area being covered. Do not let other interests distract you.
- To avoid accidents and/or injuries, please make sure there is no person around or behind the roller when use.



TO PREVENT INJURY, USE WITH CAUTION!

LIFTING HAZARD: When the roller is fully loaded with water, it weighs:

R28-1824 = 270 lbs

R76-2436 = 680 lbs



WARNING: PINCH POINTS

Use caution between the scraper bar and roller, as well as the handle.



Part List

DO NOT RETURN PRODUCT IF YOU ARE MISSING PARTS. PLEASE CALL: 1 (800) 972-6130

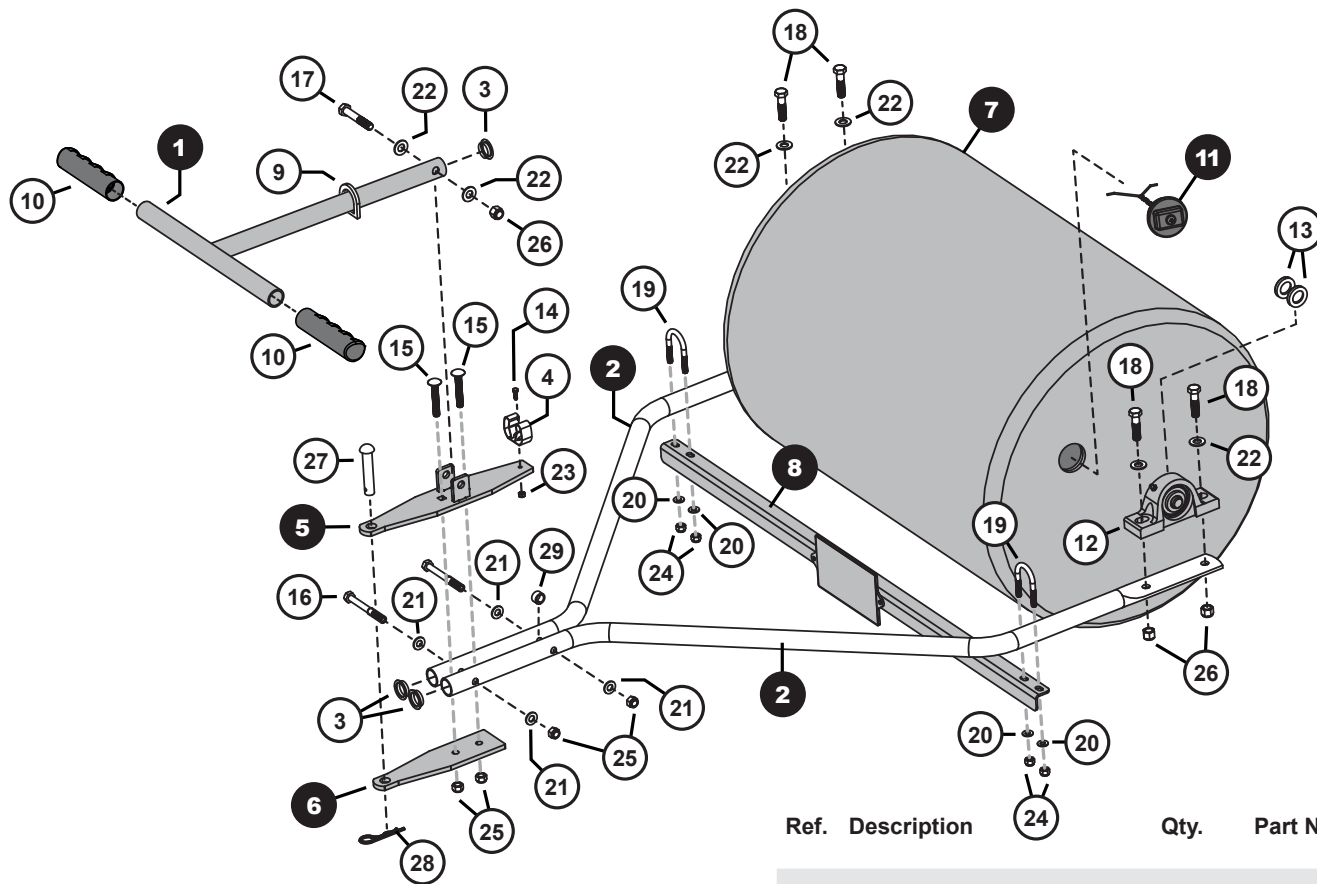

Ref.	Description	Qty.	Part No.	
			models > R28-1824	R76-2436
1	Handle Weldment	1	1019542-10	
2	Frame Tubes	2	1019540-10	1019541-10
3	Plug, Tube End	3	1019551	
5	Hitch Plate, Top	1	1019539-10	
6	Hitch Plate, Bottom	1	1019536-10	
7	Roller Drum	1	1019545	1019546
8	Scraper Bar	1	1019599	1019600
9	D-Ring	1	1019547-10	
10	Handle Grip	2	1019525	
11	Tethered Plug	1	1019524	
12	Pillow Block Bearing	2	1019534	
13	Washer; Flat, 5/8"	4	45M2121P	

Ref.	Description	Qty.	Part No.
	Bag, Hardware	1	1019535
4	Spring Clip	1	1019526
14	Bolt; Hex, #6-32 x 5/8"	1	1019567
15	Bolt; Carriage, 5/16" x 2	2	11M1032P
16	Bolt; Hex Head, 5/16" x 3	2	2M1048P
17	Bolt; Hex, 3/8-16 x 2-1/4"	1	1019565
18	Bolt; Hex, 3/8-16 x 1-1/2"	4	1019566
19	U-Bolt; 1/4"-20, 1-1/8"	2	1019569
20	Washer; Flat, 1/4"	4	45M0909P
21	Washer; Flat, 5/16"	4	45M1111P
22	Washer; Flat, 3/8"	6	45M1313P
23	Nut; Nylon Lock, #6-32	1	1019568
24	Nut; Nylon Lock, 1/4"-20	4	B-4785
25	Nut; Nylon Lock, 5/16"-18	4	B-4786
26	Nut; Nylon Lock, 3/8"-16	5	B-4820
27	Pin; Hitch, 1/2" x 2-1/2"	1	B-3861
28	Cotter; Hairpin, 1/8", #211	1	D-146P
29	Spacer; Frame	1	R-1141-01

Hardware Identifier

ILLUSTRATIONS ON THIS PAGE ARE TO SCALE FOR FASTER IDENTIFICATION OF HARDWARE DURING ASSEMBLY.

DO NOT RETURN PRODUCT IF YOU ARE MISSING PARTS. PLEASE CALL: 1 (800) 972-6130

14 Bolt; Hex
#6-32 x 5/8" (x1)
1019567

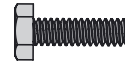

15 Bolt; Carriage
5/16" x 2" (x2)
11M1032P

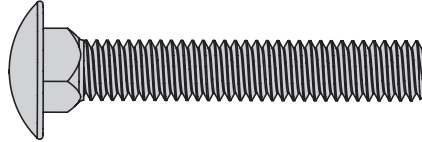

16 Bolt; Hex Head
5/16" x 3" (x2)
2M1048P



17 Bolt; Hex Head
3/8"-16 x 2-1/4" (x1)
1019565

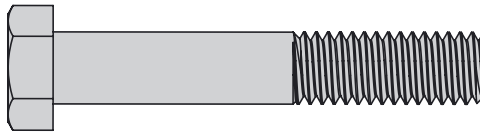

18 Bolt; Hex Head
3/8"-16 x 1-1/2" (x4)
1019566

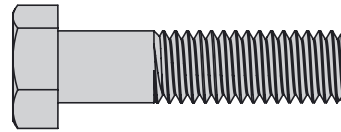

19 U-Bolt
1/4"-20, 1-1/8" (x2)
1019569

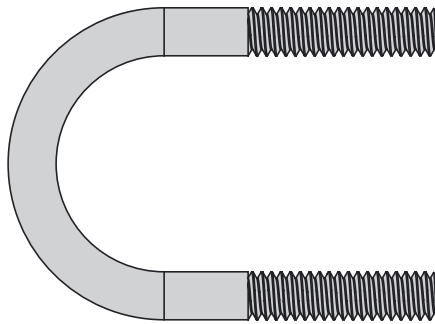

27 Hitch Pin
1/2" x 2-1/2" (x1)
B-3861



23 Nut, Nylon
Lock, #6-32 (x1)
1019568



24 Nut, Nylon
Lock, 1/4"-20 (x4)
B-4785



25 Nut, Nylon
Lock, 5/16"-18 (x4)
B-4786

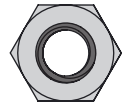

26 Nut, Nylon
Lock, 3/8"-16 (x5)
B-4820



29 Frame Spacer (x1)
R-1141-01

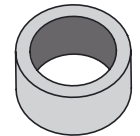

Exterior circumference of washers can vary. These dimensions are a measurement of the internal diameter of the washer.

20 Washer, Flat 1/4" (x4)
45M0909P

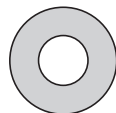

21 Washer, Flat 5/16" (x4)
45M1111P

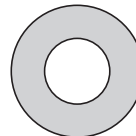

22 Washer, Flat 3/8" (x6)
45M1313P

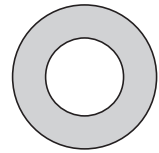

Assembly

1. On the end of the top hitch plate (5), align the spring clip (4) as illustrated below.

Run the #6 Hex Bolt (14) through the spring clip and secure beneath the hitch plate with the #6 Nylon Lock Nut (23).

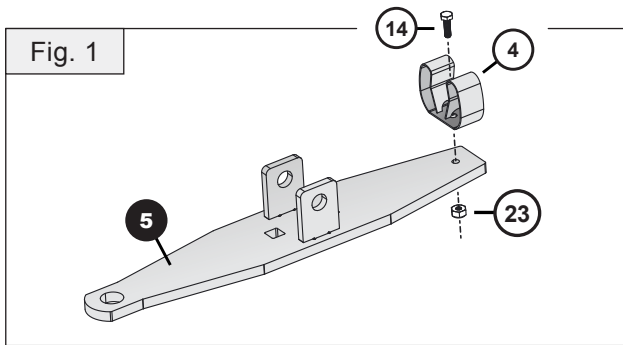

NOTE: After this point, do NOT tighten bolts fully until **Step 7**. You will need the ability to shift parts a little during the assembly.

2. Align the frame tubes (2) together and place the frame spacer (29) between them at the second set of bolt holes. See illustration.

Add a flat washer (21) to each of the 5/16" x 3" bolts (16). Run these bolts through the frame tubes (2) and add an additional flat washer (21) to each bolt.

Add a 5/16" Nylon Lock Nut (25) on each bolt and loosely tighten until both frame tubes contact the spacer, leaving a gap for Step 3.

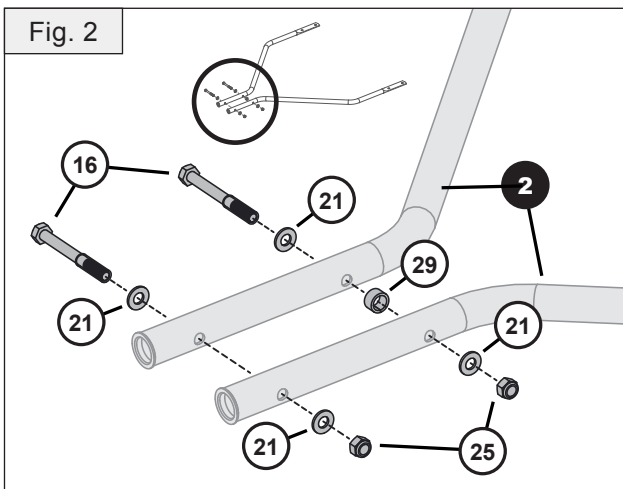

3. Align the hitch plates (5 and 6) at the end of the frame tubes.

NOTE: Bolts to be added will straddle the first bolt at the end of the tubes. (Noted here as Bolt "A")

Run two 5/16 x 2" carriage bolts (15) through the hitch plates as illustrated, straddling Bolt A.

Loosely add two 5/16" Nylon Lock Nuts (25) on each bolt.

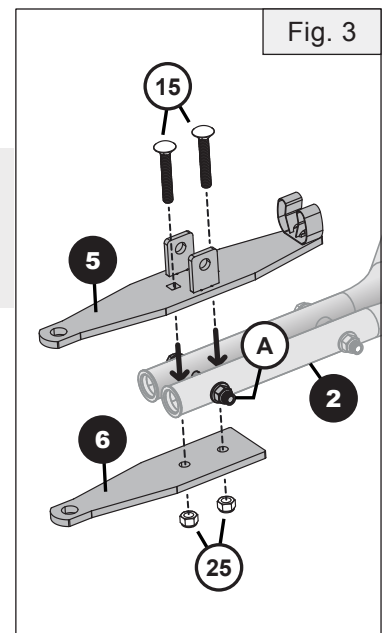

4. Align the tow tube (2) against the flat base of the roller bearing (12) as illustrated here.

Add a 3/8" Flat Washer (22) to each of the 3/8"-16 x 1-1/2" Hex Head Bolts (18) and run them through these two parts. Beneath the tow tube, loosely add a 3/8" Nylon Lock Nut (26) to each.

(See image).

Repeat this step on the other side of the roller.

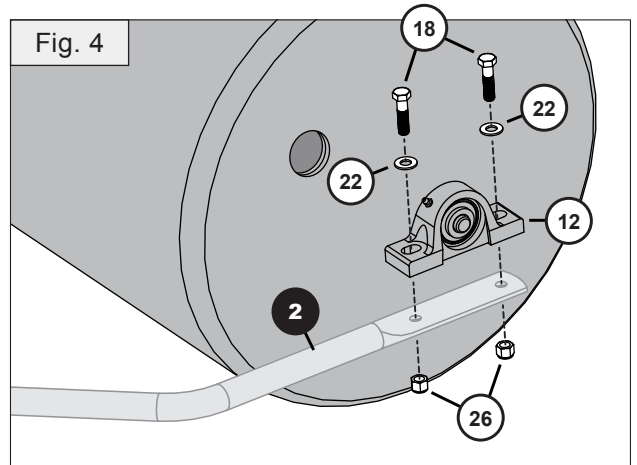
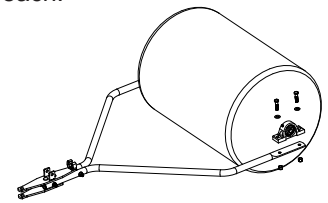

Assembly

- Align the scraper bar (8) parallel with the roller drum (but not touching), and across the frame tubes (2) as illustrated. The logo panel faces away from the roller drum.

NOTE: Leave a small gap between the bar (8) and roller (7) ensuring the scraper bar does not touch the roller at any point in one full revolution.

Slide the two U-Bolts (19) in place, straddling the frame tubes (2), running through the scraper bar (8).

Add a 1/4" flat washer (20) and add a 1/4" nylon lock nut (24) to each end of the U-Bolt, but don't tighten fully yet.

NOTE: Alternate tightening the nuts to ensure u-bolts are straight.

NOTE: Flipping the frame over, upside down, may help.

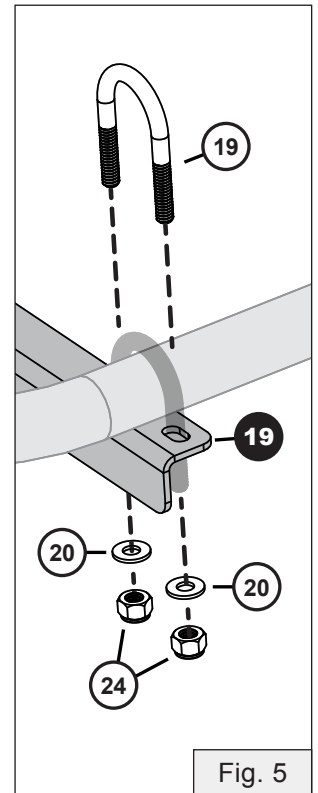
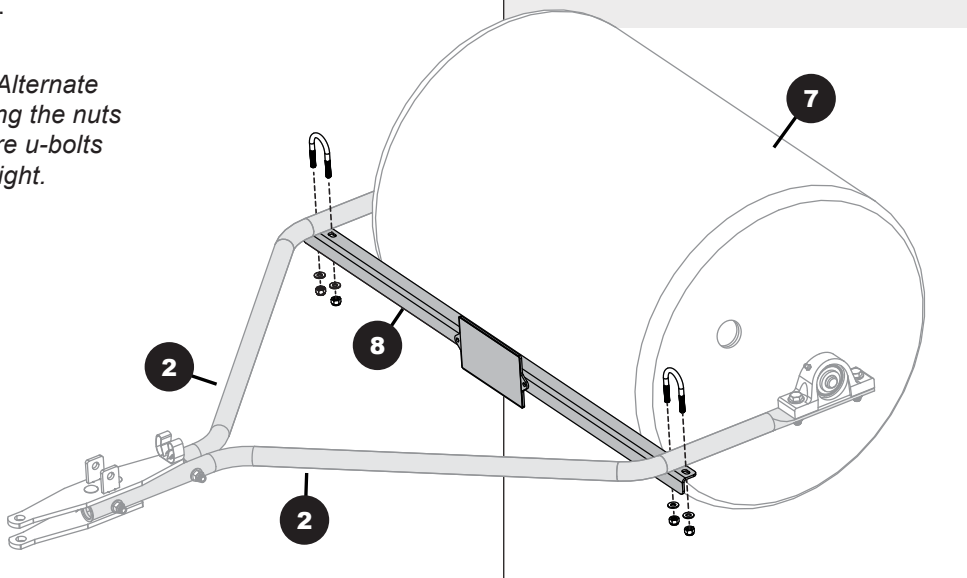
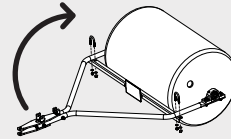

Fig. 5

- Insert the clevis pin (27) through the end of both hitch plates (5 and 6). Secure with a hairpin cotter (28).

Secure the two carriage bolts (15) beneath the lower hitch plate (6).

NOTE: The hitch pin can be stored upside down in the bottom hitch plate when using the push handle.

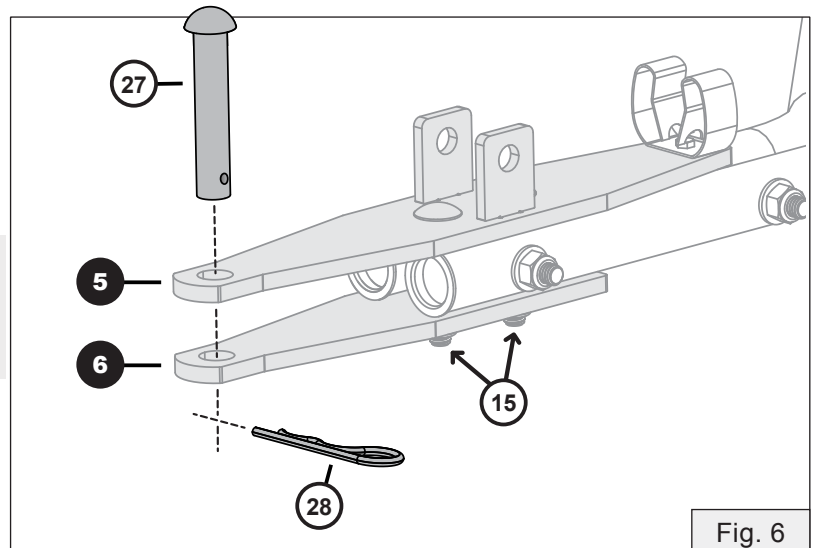
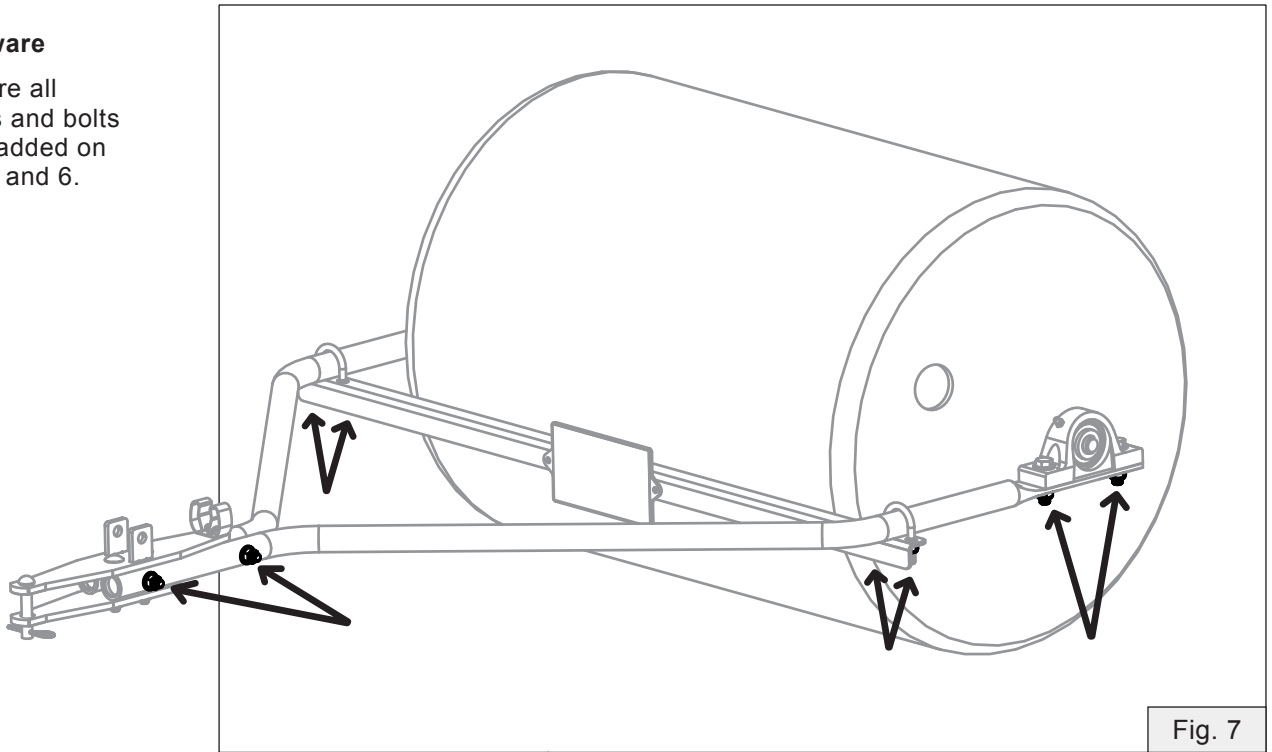

Fig. 6

Assembly

7. Securing the Hardware

Fully secure all of the nuts and bolts that were added on Steps 3, 5 and 6.



8. Insert the handle (1) through D-ring (9) and then slide the handle through the upper hitch plate (5) tabs.

Slide a 3/8" washer (22) between the handle and hitch tabs. Run the 3/8" x 2-1/4" hex head bolt (17) through and secure in place with a 3/8" nylon lock nut (26).

NOTE: Tighten firmly to reduce play but do not overtighten as handle needs to rotate.

NOTE: Resting the handle in the spring clip may help.

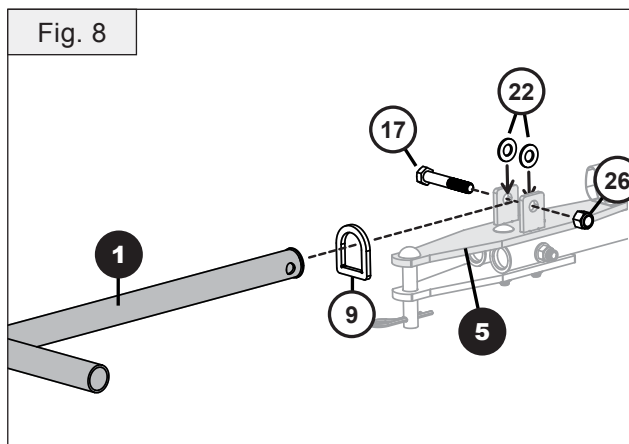

9. Attach the roller plug (11) by squeezing tether spring and insert into roller, rotating the plug in place.

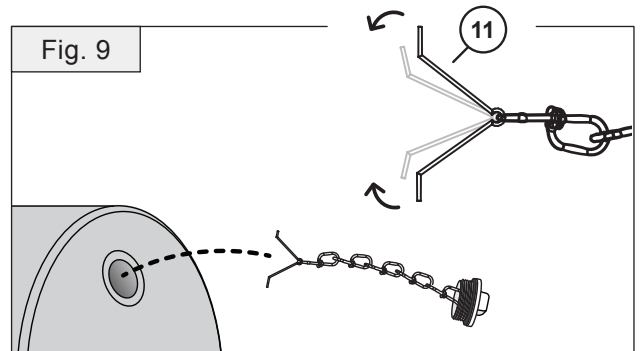

Assembly is complete.

TO PREVENT INJURY, USE WITH CAUTION: LIFTING HAZARD

When the roller is fully loaded with water, it weighs:

R28-1824 = 270 lbs R76-2436 = 680 lbs



OPERATION

- Refer to tractor manual to determine proper towing capacity of your Tractor / Rider.
- GROUND CONDITION IS VITAL TO GOOD LEVELING. Soil should be moist, but not muddy.
- Refer to your Tractor or Riding Mower owner's manual for proper towing capacity and safe operation of your towing equipment. Towing / Stopping distances will be greatly affected by added weight of roller.

- Fill the roller with the amount of water recommended for your tractor / rider. Screw in the plug and tighten securely.

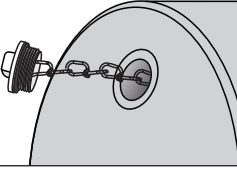

- The plug has an o-ring to create a seal and prevents the drum contents from leaking out.
- Please note that sand may be used in place of water with no risk of freezing.

Using the Handle:

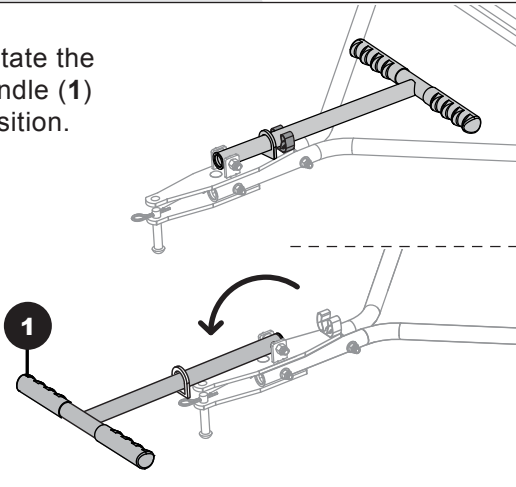
1. Rotate the handle (1) position.

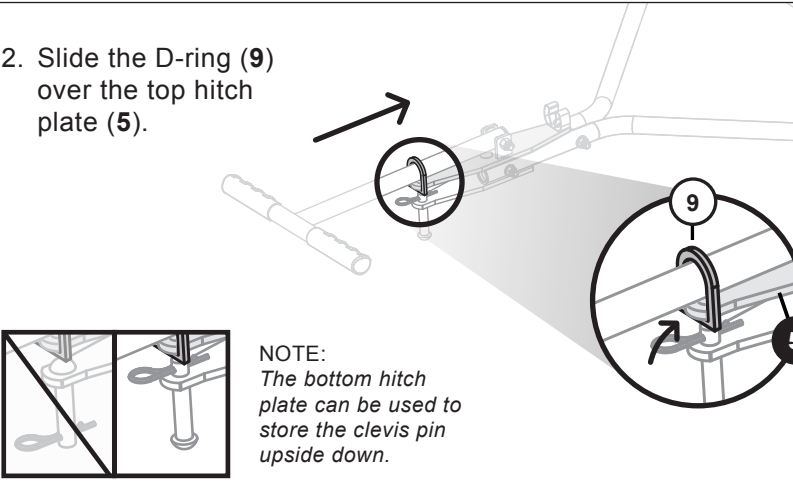

2. Slide the D-ring (9) over the top hitch plate (5).



NOTE:
The bottom hitch plate can be used to store the clevis pin upside down.

CAUTION! Avoid Damage.

Do not overload your tractor / rider. Roller fully loaded with water weighs:

R28-1824 = 270 lbs
R76-2436 = 680 lbs

WARNING: Pinch Points

Use caution between the scraper bar and roller, as well as the handle.



MAINTENANCE

- The key to years of trouble-free service is to keep your Lawn Roller clean and dry.
- Should any rust develop, sand lightly and then paint the area with enamel.
- Periodically check all fasteners for tightness.
- Lubricate bearings monthly with general purpose lithium grease. Using the grease fittings on the bearings, ensure grease fitting is clean prior to lubricating. If used in a very dirty / wet environment, lubricate bearings weekly.

NOTE: It's best to rotate axle while lubricating. Bearings are fully greased when grease comes out the bearing seals on the sides.

TRACTOR / RIDING MOWER SPEED



Rollers yield the best results when ground conditions are correct, and equipment is operating at **less than 3 mph**.

CALIBRATING YOUR TRACTOR TO 3 MPH:

Measure a distance of 20 feet on a flat, level surface. Adjust tractor throttle and select a gear to cover this distance in 4.5 seconds.

STORAGE

For longest life:

- ✓ Drain the roller
- ✓ Leave the plug out
- ✓ Grease bearings prior to long term storage.
Refer to maintenance section.
- ✓ If possible, hang the roller when not in use to prevent possibility of developing a flat spot.

If a flat spot develops on the roller during storage, ensure that the roller is empty then leave out in the sun to warm and roll around to reduce flat area.

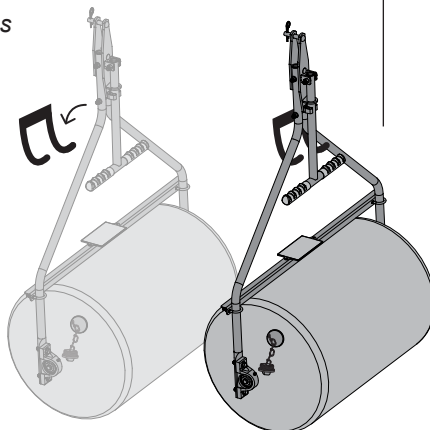

SERVICE

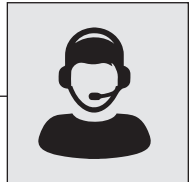

QUALITY CONTINUES WITH QUALITY SERVICE

If you have installation questions, are missing parts or need replacement parts, don't go back to the store!

Please find your product serial number and model number, then contact our Customer Service department:

 In North America and Canada call
Toll-Free: 800-972-6130

 Chat online: www.spyker.com



WARRANTY

1 YEAR LIMITED WARRANTY

This is warranted to the original purchaser only. Spyker will replace parts with defects in materials and workmanship, for a period of one year from the date of purchase.

Spyker Spreaders will not be liable for any loss, damage or expense including, but not limited to, consequential or incidental damages, arising from the operation, condition or use of the item. The sole and exclusive remedy against Spyker Spreaders being the replacement of the defective parts. This warranty gives you specific legal rights, and you may also have other rights which vary from state to state.

This express warranty, which is applicable only to the original purchase, is in lieu of and excludes all other warranties, whether expressed or implied by operation of law or otherwise, including any warranty of merchantability or fitness for particular purpose.

SPYKER SPREADERS
Jeffersonville, IN 47130 USA
Phone: 800.972.6130
www.spyker.com